

teach with space

→ SPACECRAFT MATERIALS KIT

Discovering the different properties of materials

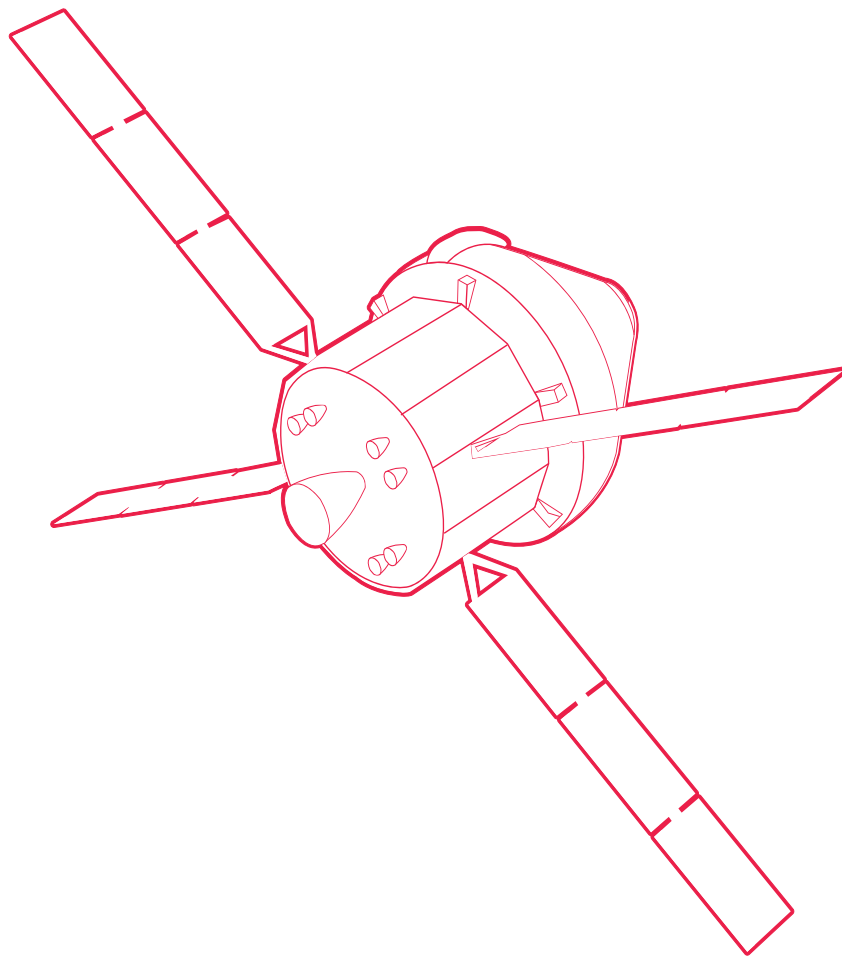

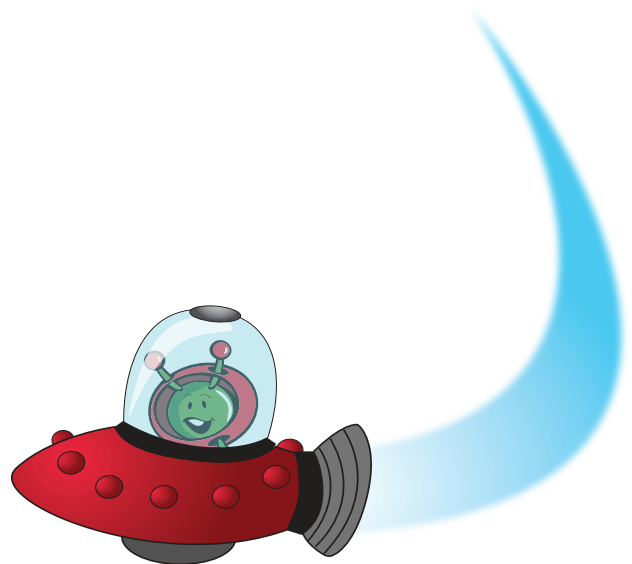

Exploring materials - look and feel	page 3
Activity 1 - electrical conductivity	page 5
Activity 2 - thermal conductivity	page 7
Activity 3 - measuring mass	page 9
Activity 4 - magnetism	page 11
Activity 5 - impact test	page 13
Classroom discussion	page 16

→ EXPLORING MATERIALS – LOOK AND FEEL

Did you know?

NASA's Orion **Spacecraft*** is built to take humans further into deep space than they have ever gone before. The European Space Agency (ESA) is developing Orion's European Service **Module*** which is the part of the spacecraft that will supply air to the crew, as well as electricity and **propulsion***. This will enable it to travel out into space.

The image on the right shows the Orion Spacecraft – developed by NASA and ESA (artist's impression).



A spacecraft is made of several different materials. An ESA scientist is going to challenge you to carry out a number of activities to investigate the properties of some materials. You will give reasons why these properties would make them suitable to build a spacecraft like Orion.

Watch the video of the challenge you are about to carry out.



Discuss with your classmates why some materials are used for some things and not for others. Then you will be ready to start your experiments! In addition to 8 cubes of materials, you will also test another 'special' cube of material, but return this to your teacher once you have finished. Before you begin make sure that your desk is protected with thick paper or cloth.

↑ The challenge from ESA scientist

Equipment

- 1 set of cubes 2 cm x 2 cm x 2 cm of different materials

Exercise

1. Look carefully at the different materials, and by feeling them with your hands, try to think what they may be.
2. Group the materials under observations such as heavy/light; rough/smooth; warm to touch/cool; shiny/dull.
3. Write down your observations in the table on the next page.

* **Spacecraft**: vehicle used for travelling in space e.g. the International Space Station and Orion spacecraft.

Module: detachable, self-contained unit of a spacecraft.

Propulsion: force that pushes a spacecraft into space.

Your results

<i>material</i>	<i>look and feel</i>
 Copper	
 Aluminium	
 Brass	
 Steel	
 Wood	
 Stone	
 Plastic	
 Polystyrene	
 Aluminium alloy (6061)	

4. Think of reasons why you have organised the groups in this way.

5. Suggest tests you could perform to compare the materials.

Conclusion

Write down your first conclusions about the diversity of materials.



→ ELECTRICAL CONDUCTIVITY

The material to be used around the electrical components of the spacecraft needs to be a good **electrical conductor***, so that it can conduct away electrical charge, which could otherwise damage the components.

Did you know?

The Orion European Service Module has four wings. They are made of solar panels that collect the energy of the Sun, which is then transformed into electricity. This electricity is used to power the computers and the other instruments and tools on-board the module. This electricity would be enough to power two typical houses!



Equipment

- 1 set of cubes 2 cm x 2 cm x 2 cm of different materials
- 1 battery (AA)
- 1 battery holder connected to one red wire and one black wire
- 1 bulb
- 1 bulb holder
- 2 connecting wires with crocodile clips

Exercise

1. Set up the circuit as shown in Figure A2.
2. Make sure the light bulb lights up when you put the crocodile clips against the contacts of the light bulb.
3. You have built an electrical series circuit.
4. Now change the setup as in Figure A3. Touch the crocodile clips firmly on to the material to make sure you establish a good contact. Do not pinch them as you may damage the materials.
5. Test each cube in turn to see if the bulb lights up.
6. Write down your results in the table on the next page.

The material that conducts electricity is called an electrical conductor and the material that does not is called an **insulator***.

***Electrical conductor**: material which allows the flow of electric current e.g. metal.

Insulator: material which does not allow the flow of electric current e.g. plastic and wood.

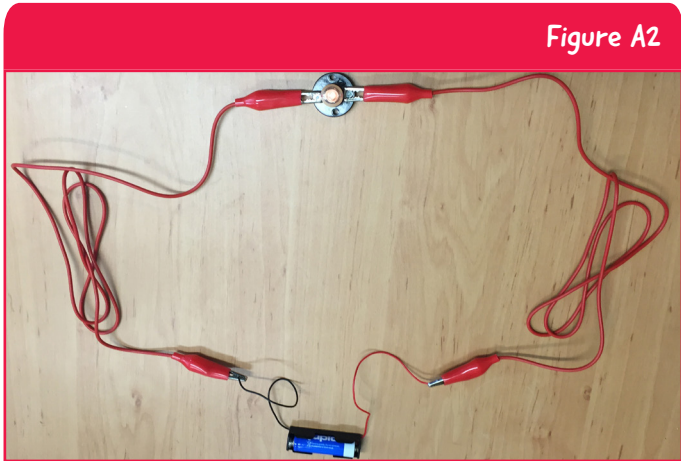

Figure A2

↑ Setup to test light bulb

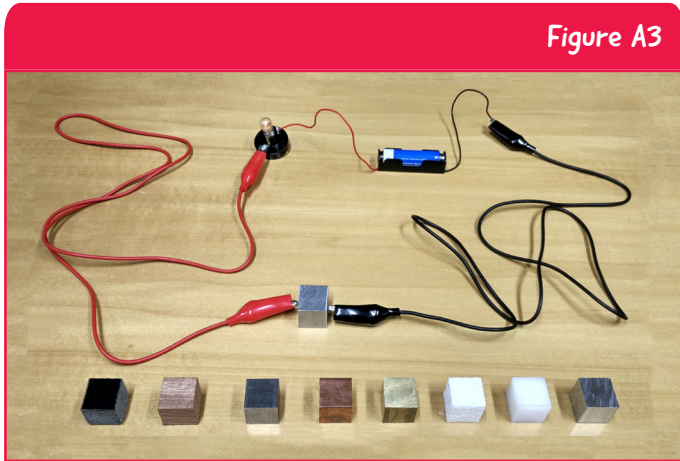











Figure A3

↑ Setup to test cubes

Your results

material	conductor or insulator
 Copper	
 Aluminium	
 Brass	
 Steel	
 Wood	
 Stone	
 Plastic	
 Polystyrene	
 Aluminium alloy (6061)	

Conclusion

Explain why some materials caused the bulb to light up and others did not?

→ THERMAL CONDUCTIVITY

Equipment and crew on board spacecraft such as Orion need to be kept safe and comfortable in the extreme temperatures of space. Materials that can cope with very high and low temperatures are necessary for this purpose. Usually these materials are good thermal conductors.

Did you know?

The Orion Crew Module is the part designed to re-enter Earth's atmosphere, so it has a heat shield to protect it (and the crew!) against the intense **heat of re-entry***. This principle is shown in the image on the right.



Equipment

- 1 set of cubes 2 cm x 2 cm x 2 cm of different materials
- 8 squares of thermochromic paper, including cover slips
- 2 petri dishes
- Hot water from kettle (which will be poured by your teacher) - be careful not to touch this

Exercise

1. Place a square of thermochromic paper over each of the cubes to be tested (which should all be at room temperature).
2. Your teacher will pour hot water into 2 petri dishes – then carefully cover with the lids.
3. Place the cubes on top of the lid of a petri dish as shown in Figure A4.
4. Carefully and patiently observe the thermochromic paper and note down which ones change colour first.
5. Rank the materials according to their thermal conductivity: from those that allow heat to conduct fastest (1) to slowest (9).
6. Write down your answers in the table on the next page.

*Heat of re-entry: heat generated by the re-entry of a spacecraft in the atmosphere; temperatures can reach 1650° C or more.





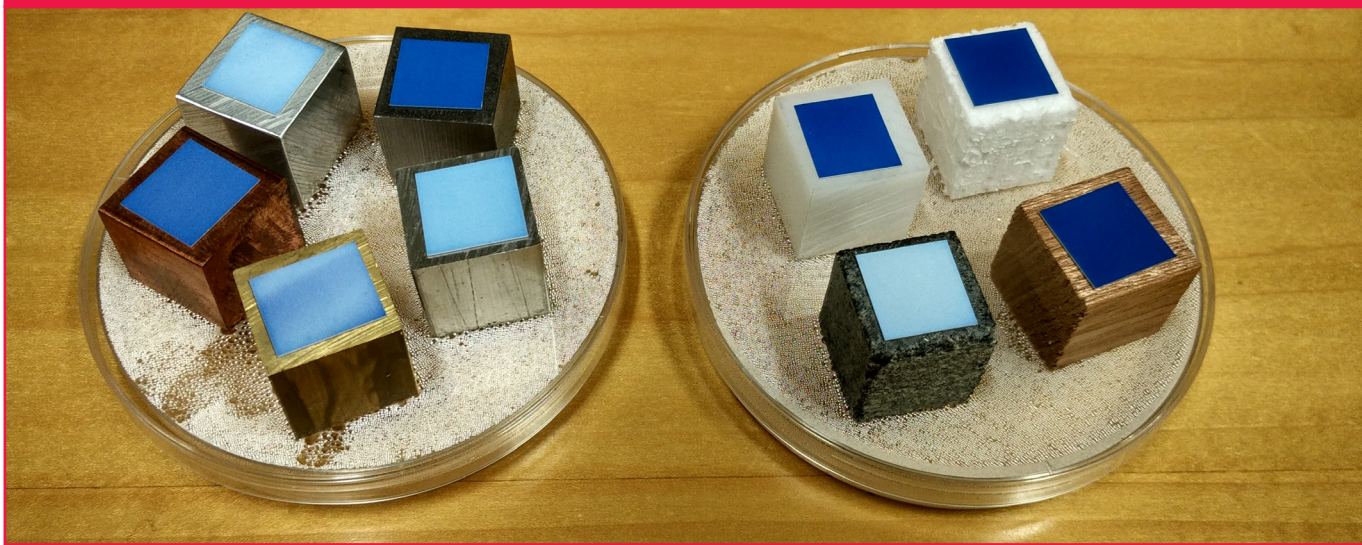





Figure A4



↑ Thermal conductivity test

Your results

material	ranking (1-9)
 Copper	
 Aluminium	
 Brass	
 Steel	
 Wood	
 Stone	
 Plastic	
 Polystyrene	
 Aluminium alloy (6061)	

Conclusion

Explain which of these materials is best at allowing thermal conductivity.

→ MEASURING MASS

It takes a lot of **rocket fuel*** to launch a spacecraft into space and this is also very expensive. We need materials which are strong, stiff, and have a low mass (light in weight) to build the spacecraft.

Did you know?

The Orion Crew Module shown in the image on the right is a reusable transportation vehicle that provides a safe **habitat*** for the crew. It is the only part of the spacecraft that returns to Earth after each mission. With a mass of about 8500 kg, it is covered with special fibres made of silica with a **resin*** in a **honeycomb*** made of fiberglass and **phenolic resin***: very unusual materials indeed!



Equipment

- 1 set of cubes 2 cm x 2 cm x 2 cm of different materials
- 1 digital scale

Exercise

1. Hold each cube one at a time and rank them according to which you think is the lightest (1) to the heaviest (9).
2. Now use the digital scale to weigh each cube and record the real mass (in grams to one decimal place) as shown in Figure A5. Define the actual ranking based on the real mass.
3. Write down your answers in the table on the next page.



Figure A5



↑ Measuring mass accurately



Your results

material	my ranking (1-9)	real mass (g)	actual ranking (1-9)
 Copper			
 Aluminium			
 Brass			
 Steel			
 Wood			
 Stone			
 Plastic			
 Polystyrene			
 Aluminium alloy (6061)			

Conclusion

Compare your ranking with the actual ranking and give an explanation why this was similar or different.

Discuss which of the materials, only based on the mass, would be most suitable for designing a spacecraft and why.

***Rocket fuel:** explosive charge that propels a rocket e.g. liquid oxygen and liquid hydrogen.

Habitat: place or environment where humans, animals, and plants can live.

Resin: yellow or brown sticky substance that comes from some trees and used to make various products.

Honeycomb: network of close-fitting hexagonal cells that create a very strong structure which is also light in weight.

Phenolic resin: very strong synthetic substance used for its strong temperature tolerance.

→ MAGNETISM

When moving in space, it can be helpful if the material making up the spacecraft is non-magnetic. Materials in spacecraft which are magnetic need to be avoided because they can disturb instruments such as the onboard orientation device, which uses the Earth's magnetic field to point the spacecraft in the right direction.

Did you know?

The Earth's core, or centre, is made up of molten iron, which being magnetic, causes the Earth to behave like a gigantic magnet. This has an impact on magnetic materials such as the metal of a compass' arrow. We can use a compass to navigate outdoors using a map as it will always point North on the dial.

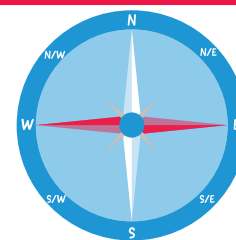

Equipment

- 1 set of cubes 2 cm x 2 cm x 2 cm of different materials
- 1 magnet

Exercise

Test which of the materials interact with a magnet (this interaction is called magnetism), and which materials do not, as shown in Figure A6. Write down your results in the table on the next page.

Figure A6

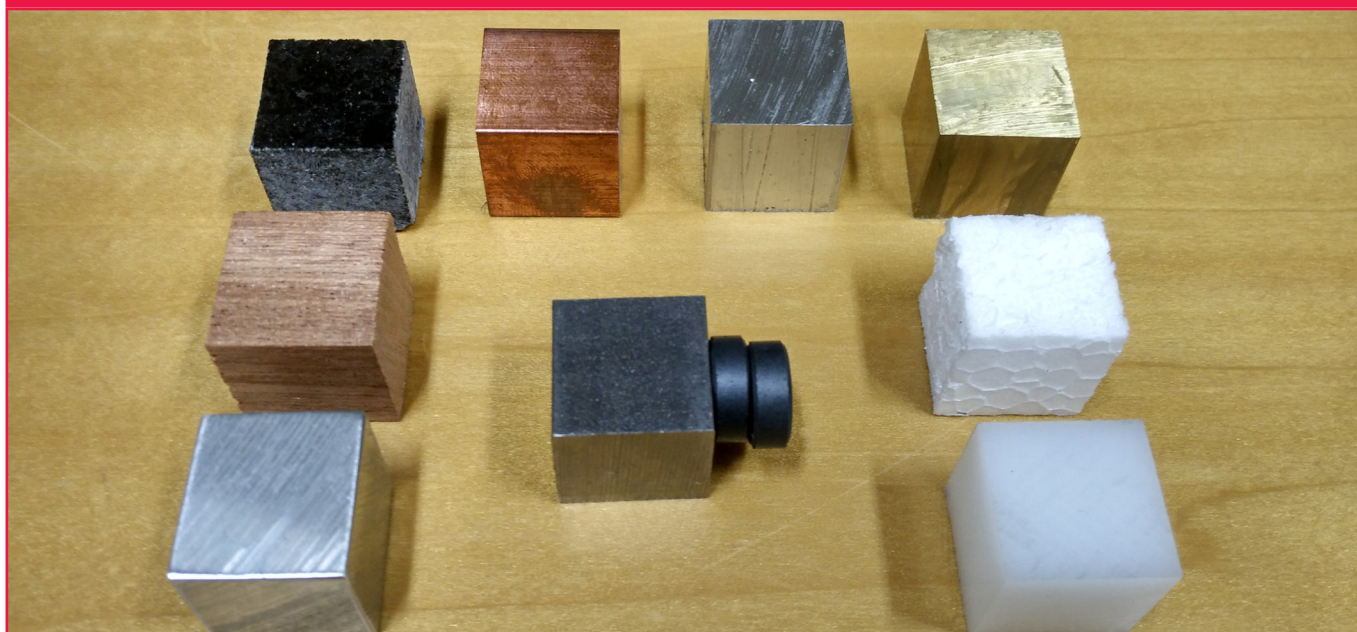

↑ Testing for magnetic attraction



Your results

<i>material</i>	<i>magnetic or non-magnetic</i>
 Copper	
 Aluminium	
 Brass	
 Steel	
 Wood	
 Stone	
 Plastic	
 Polystyrene	
 Aluminium alloy (6061)	

Conclusion

Which materials are not magnetic? Explain why they are not.

→ IMPACT TEST

Spacecraft such as **satellites*** can be hit by **space debris*** travelling at very high speeds. We need to use tough materials which can resist such **impacts***. You are going to use a special ramp to measure the rebound after a marble impacts each test material. The more the rebound, the less the damage to the material.

Did you know?

More than 500 000 (five hundred thousand) pieces of space debris (also known as 'space junk'), made up of old satellites and natural space rocks, are being tracked around the Earth. They can be the size of a marble or larger. But there are millions of other pieces that are so small they cannot be tracked. These are serious threats to satellites and space vehicles, as they travel at very high speeds and can cause a lot of damage!

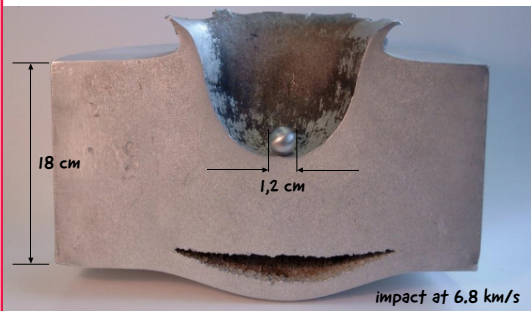
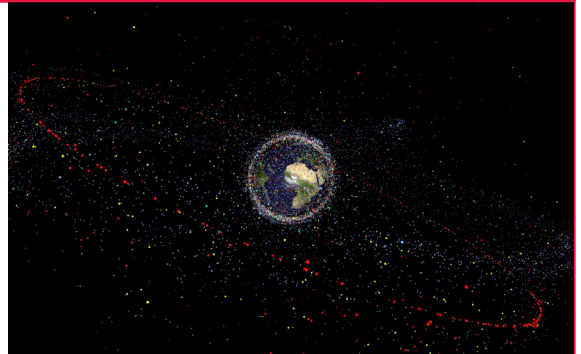

Look at what happened in tests carried out on a spacecraft material being hit by a fast moving pellet (shown in the image on the left). Orion's European Service Module provides a strong structure which is covered in many layers of materials that helps to reduce the damage of such impacts.

Equipment

- 1 set of cubes 2 cm x 2 cm x 2 cm of different materials
- 1 ramp set
- 1 marble

Exercise

1. If it has not already been constructed, put together the special ramp set from the pieces provided, as shown in Figure A7.
2. Place each cube of material, one at a time, at the bottom of the ramp.
3. Push the marble gently off the top of the ramp.
4. Measure the rebound (in millimetres) when the marble strikes the cube at the base of the ramp.

***Satellites (artificial):** objects put into orbit (which is a repeated path) around the Earth or another planet. Satellites are designed to take measurements and pictures which will, for instance, help scientists learn more about the Earth, planets, and beyond.

Space debris: pieces of old satellites, used rocket parts, fragments of space rocks etc. which are travelling at high speeds of up to 28,000 km/hr around the Earth.

Impact: collision of space debris with satellites or spacecraft like the International Space Station which can cause damage due to the high speed at which they travel.



5. Repeat this for each material. How can you make this a fair test?

6. Repeat the test 3 times for each cube and calculate the mean (average) rebound.

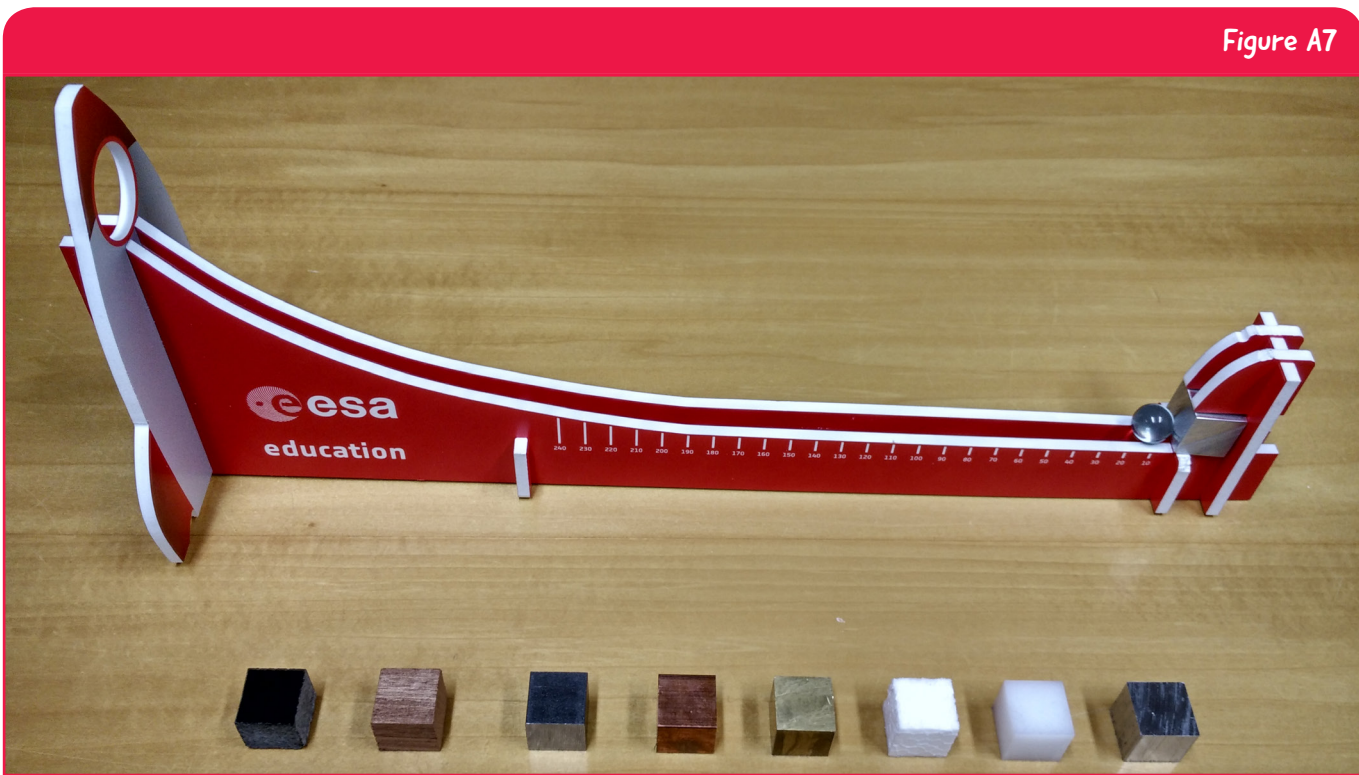











Figure A7

↑ The impact test



Your results

Record all your measurements below. At the end, fill in the last column by ranking the average rebound from the largest (1) to the smallest (9). Remember: the larger the rebound, the less damage you will do to the material.

material	rebound measurements (mm)			mean rebound value =	rebound ranking (1-9)
	A	B	C	$\frac{A + B + C}{3}$	
 Copper					
 Aluminium					
 Brass					
 Steel					
 Wood					
 Stone					
 Plastic					
 Polystyrene					
 Aluminium alloy (6061)					









Conclusion

Write down which of the materials gave the best rebound and explain why.

→ CLASSROOM DISCUSSION

Which materials appear to be best suited for a spacecraft?

1. Fill in the results of all your activities in the table below.

material	look and feel	electrical conductivity (Yes/No)	thermal conductivity (ranking)	measuring mass (g)		magnetism (Yes/No)	measuring impact rebound	
				(g)	(ranking)		(mm)	(ranking)
 Copper								
 Aluminium								
 Brass								
 Steel								
 Wood								
 Stone								
 Plastic								
 Polystyrene								
 Aluminium alloy (6061)								

2. Based on the results that you have written in the table above, write down your full conclusions on what material appears to be best suited for each part of a spacecraft and why.

teach with space – spacecraft materials kit | PR07b
www.esa.int/education

Concept developed for ESA by Nottingham Trent University, UK

The ESA Education Office welcomes feedback and comments
teachers@esa.int

An ESA Education production
Copyright © European Space Agency 2017