

teach with space

→ SPACECRAFT MATERIALS KIT

Discovering the different properties of materials

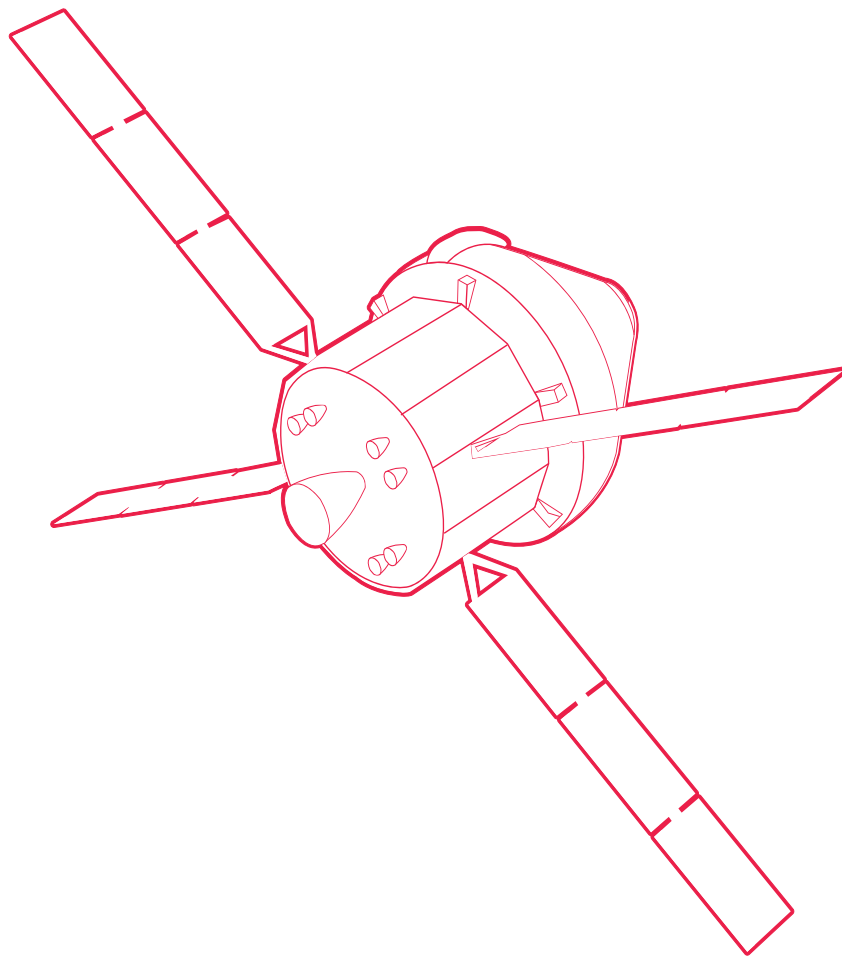



Fast facts	page 3
Background on the kit	page 4
Exploring materials: Look and feel!	page 5
Activity 1 - electrical conductivity	page 6
Activity 2 - thermal conductivity	page 7
Activity 3 - measuring mass	page 8
Activity 4 - magnetism	page 9
Activity 5 - impact test	page 10
Classroom discussion	page 11
Appendix	page 12
Glossary	page 12
Links	page 13

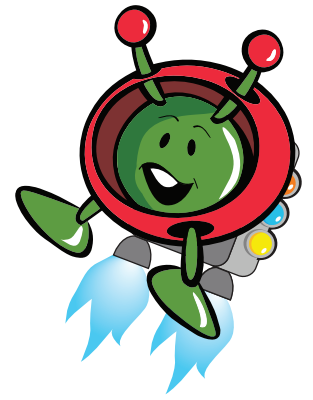

→ SPACECRAFT MATERIALS KIT

Discovering the different properties of materials

FAST FACTS

Age range: 8–12 years old

Type: group activity

Complexity: easy

Teacher preparation time: 30 minutes

Lesson time required: 1 - 2 hours

Cost per activity: low (less than 10 euros)

Location: indoor (any classroom)

Includes the use of: computer with digital board

Outline

The ESA Spacecraft Materials Kit for primary schools is a useful resource that can be used by pupils to investigate a range of materials using a spacecraft theme. Using a set of 9 different materials, they will investigate which properties are best suited for parts of a spacecraft such as the Orion space vehicle.

On the resource webpage (www.esa.int/spacecraft_materials_kit) you can find short video demonstrations of how to set up the activities, this teacher guide, pupil activity sheets, and a PowerPoint presentation. The PowerPoint presentation introduces a video challenge to pupils from an ESA scientist. Pupils can then perform the activities. The software 'Crazytalk' has been used to communicate a message to pupils from Michael Faraday (electrical conductivity), Archimedes (measuring mass) and James Joule (thermal conductivity).

Pupils will learn

To compare and group together everyday materials on the basis of their properties: resistance to impacts, magnetism, electrical and thermal conductivity, and measuring mass.

Pupils will improve

- How to plan experiments to answer questions including recognising and controlling variables where necessary
- How to take measurements, using a range of scientific equipment, with increasing accuracy and precision
- How to take repeat readings when appropriate
- How to record data and results using scientific communication tools
- How to report and present findings from experiments in oral and written form
- How to identify scientific evidence that can be used to support or refute ideas or arguments



→ BACKGROUND ON THE KIT

There are eight different materials for pupils to test and explore. These are a mixture of metals and non-metals. Each is a 2 cm x 2 cm x 2 cm cube made of one of the following materials: wood, stone, aluminium, copper, polystyrene, plastic and the alloys brass and steel.

An alloy is a mixture of two or more elements, one of which is a metal. Brass is an alloy of copper and zinc, and steel is a mixture of iron and carbon. A special ninth material, an alloy called Al6061 (which is used in actual spacecraft) is also included. Al6061 is used for boxes around electronic equipment and also for mirrors. This cube is handed out, when appropriate, to each group in turn.

As alloys may not be familiar materials, this adds an additional challenge for pupils. Pupils can investigate how each of these materials responds to the tests below. These tests can be done in any order. Pupils can make reasonable suggestions regarding which of these materials is most suited for various parts of a spacecraft, such as the Orion space vehicle (useful links about this spacecraft and the mission are found in the Appendix).

The tests include measuring mass and testing for magnetic attraction, resistance to impact, and electrical and thermal conductivity. The following resources give detailed explanations on how to set up and carry out each test:

- *Teach with space | spacecraft materials kit PR07c* PowerPoint presentation
- *Teach with space | spacecraft materials kit VPR07a* demonstration video

Before beginning this practical activity, explain to the pupils the objective of the activity. Show them the ESA challenge video (Spacecraft materials kit - the challenge | VPR07b). You could talk to them more about what characteristics spacecraft materials should have. Alternatively you could let pupils try out the experiments, and then come to their own conclusions about the ideal characteristics of spacecraft materials.

We advise that you cover tables with paper or card to avoid them getting damaged by the hard cubes. The exposed ends of wires may become frayed after a while - you can simply twist them back together if this occurs.

→ EXPLORING MATERIALS: LOOK AND FEEL!

Start by distributing the activity sheets (*teach with space / spacecraft materials kit PR07b*) to the pupils and dividing them into groups. Next, explore pupils' prior knowledge about metals and non-metals and preconceived ideas related to why some materials are suitable for some things and not for others. Examples: why a car is usually mostly made of metal, yet some parts are also made of plastic; why spoons can be plastic and metal, but not glass.

Equipment

- 1 set of cubes 2 cm x 2 cm x 2 cm of different materials per group

Exercise

1. Ask pupils to group the materials by look and feel and to justify why they have organised the groups as they have. Pupils can write down their answers on the activity sheet.
2. Pupils should use scientific vocabulary as they describe the materials by look and feel (e.g. heavy/light; rough/smooth; warm to touch/cool; shiny/dull).
3. Ask pupils to suggest tests they could perform to compare the materials. Ask them what materials and instruments they would need to carry out these tests.

→ ELECTRICAL CONDUCTIVITY

Pupils will test which of the materials supplied are electrical conductors and which are insulators (do not conduct electricity). They can use scientific vocabulary such as conductors, insulators, and series circuits. They test each material in a circuit and observe if the bulb lights or not (Figures 1 and 2). The crocodile clips need to be firmly pressed onto the material, but not pinched, as they may damage some materials. The relative brightness of a bulb wired in series serves as an indication of the strength of current flow.

Equipment

- 1 set of cubes 2 cm x 2 cm x 2 cm of different materials
- 1 battery (AA)
- 1 battery holder
- 1 bulb
- 1 bulb holder
- 2 connecting wires with crocodile clips

Exercise

1. Pupils record their results and rank them according to conductors and insulators.
2. Discuss which of the materials tested would be suitable for use in a spacecraft, and where this property may be useful.

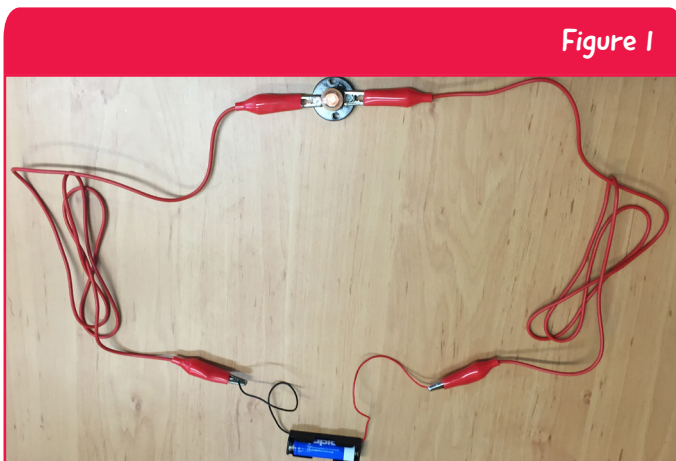

Figure 1

↑ Setup to test light bulb

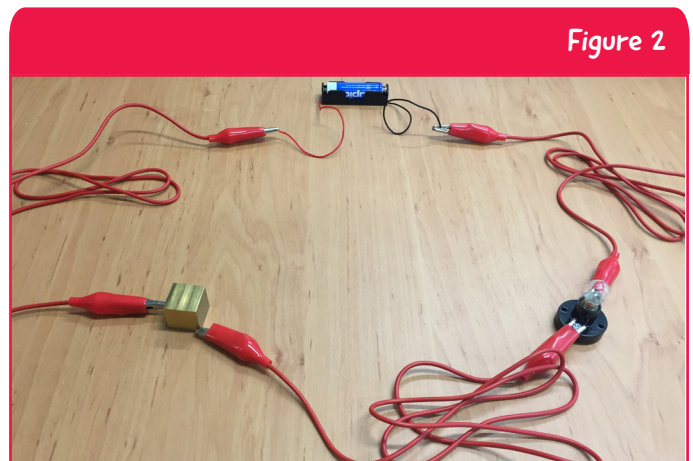

Figure 2

↑ Setup to test light cubes

→ THERMAL CONDUCTIVITY

In this heat test activity, pupils will investigate which materials are good thermal conductors using thermochromic paper (Note: different types of paper will show different colour changes, like in the demonstration video; the thermochromic paper included responds rapidly to heat by changing colour from blue to white).

Discuss when thermal conductivity is essential, for example, when the crew inside the Orion module need to be kept at the right temperature in the environment of space.

Equipment

- 1 set of cubes 2 cm x 2 cm x 2 cm of different materials
- 8 squares of thermochromic paper including cover slips, of side length approximately 1.5 cm
- 2 petri dishes
- Hot water from kettle, at 100° C

Exercise

1. Place a square of thermochromic paper over each of the cubes to be tested (which should all be at room temperature).
2. Pour hot water into each petri dish for the pupils. Place the lids on top of the dishes.
3. Carefully place the cubes on top of the lid of a petri dish (Figure 3).
4. Pupils observe how quickly each square changes colour when cubes are placed on the petri dish lids. Pupils will need to be patient during this step.
5. They can rank the materials from those that conduct the heat fastest (1) to slowest (9).
6. They may repeat the test after an initial attempt to check if their order is accurate, or use the class results as an average.
7. Pupils write their discoveries on their activity sheets.

Health and safety

The use of a kettle and hot water means that only the teacher should carry out this process.

Figure 3

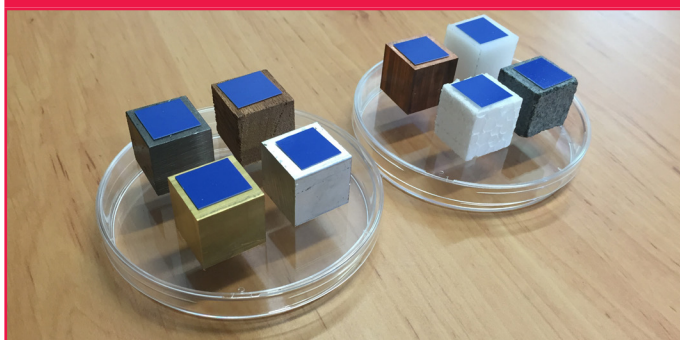

↑ Setup to test thermal conductivity



→ MEASURING MASS

Pupils compare the mass of the different materials. They can compare by the feel of the material and try ranking them from lightest to heaviest. They can then use the digital scale provided to measure the mass in grams to one decimal place.

Equipment

- 1 set of cubes 2 cm x 2 cm x 2 cm of different materials
- 1 digital scale

Exercise

1. Ask pupils to weigh the cubes in their hands, one at a time, and rank them according to how heavy they think they are, from lightest (1) to heaviest (9). Pupils can write this down on the activity sheet.
2. Ask pupils to weigh each cube, using a digital scale, to the nearest decimal place (Figure 4), and to record the mass on the pupil activity sheet.
3. Ask them if their ranking by 'feel' was different or similar to when the real mass was measured, and to give reasons for this.
4. Discuss which of these materials is most suitable for designing a spacecraft and why.

Figure 4



↑ Setup for measuring mass.

→ MAGNETISM

Pupils are provided with a magnet to test which of the materials are magnetic. They may be aware that magnetic materials are always metal, and that only metals containing iron are magnetic.

Equipment

- 1 set of cubes 2 cm x 2 cm x 2 cm of different materials
- 1 magnet

Exercise

1. Using the magnet provided, pupils test each material in turn and note down which is magnetic and which is not (Figure 5).
2. After testing each material, they record their findings in their activity sheet and predict which of the materials tested is most suitable for use in a spacecraft.
3. They can group them as magnetic or non-magnetic in the activity sheet.
4. Discuss which materials are magnetic and why.

Figure 5

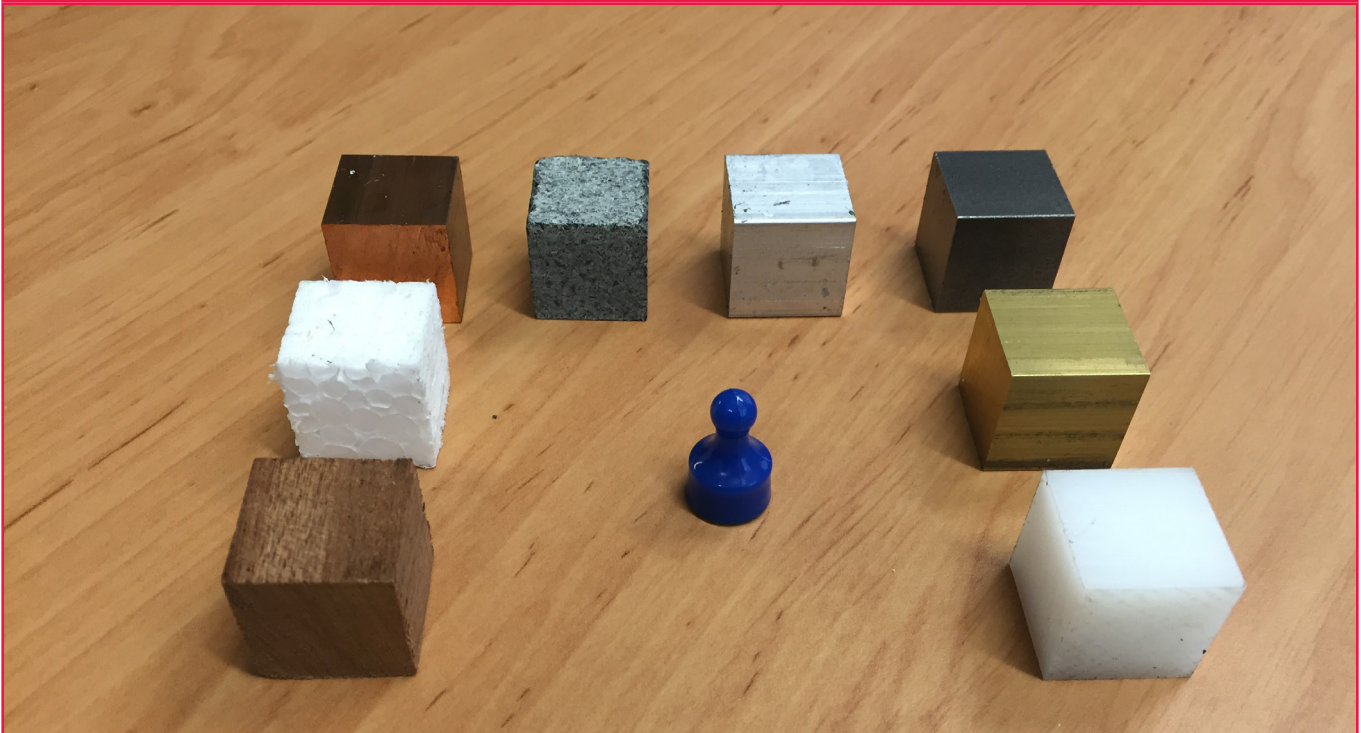

↑ Setup for magnetic test



→ IMPACT TEST

Pupils will test which materials can withstand impacts using a specially designed ramp. They can observe and measure the rebound (in millimetres) from each of the material cubes when a marble hits it. They will understand that if a material produces a bigger rebound of the marble, it is more resistant to impact, and therefore will suffer less damage on impact. A material with a smaller rebound, will suffer greater damage on impact. Pupils test which of the materials cope best with impacts: the answer is those which give the maximum rebound.

This activity will enable pupils to conduct a fair test by thinking about the position of, and the nature of, the release of the marble on the ramp. They may take repeated measurements and calculate the average of the rebound distance along the ramp.

Equipment

- 1 set of cubes 2 cm x 2 cm x 2 cm of different materials
- 1 ramp set (can be put together by the teacher or by each group of pupils)
- 1 marble

Exercise

1. Pupils conduct the impact test for each of the material cubes using the ramp provided (Figure 6), and record their measurements in the activity sheet.
2. The materials can be ranked with 1 as giving the maximum rebound and 9 as giving the least rebound.
3. Discuss which gave the best rebound results and how this would be useful in spacecraft.

Figure 6

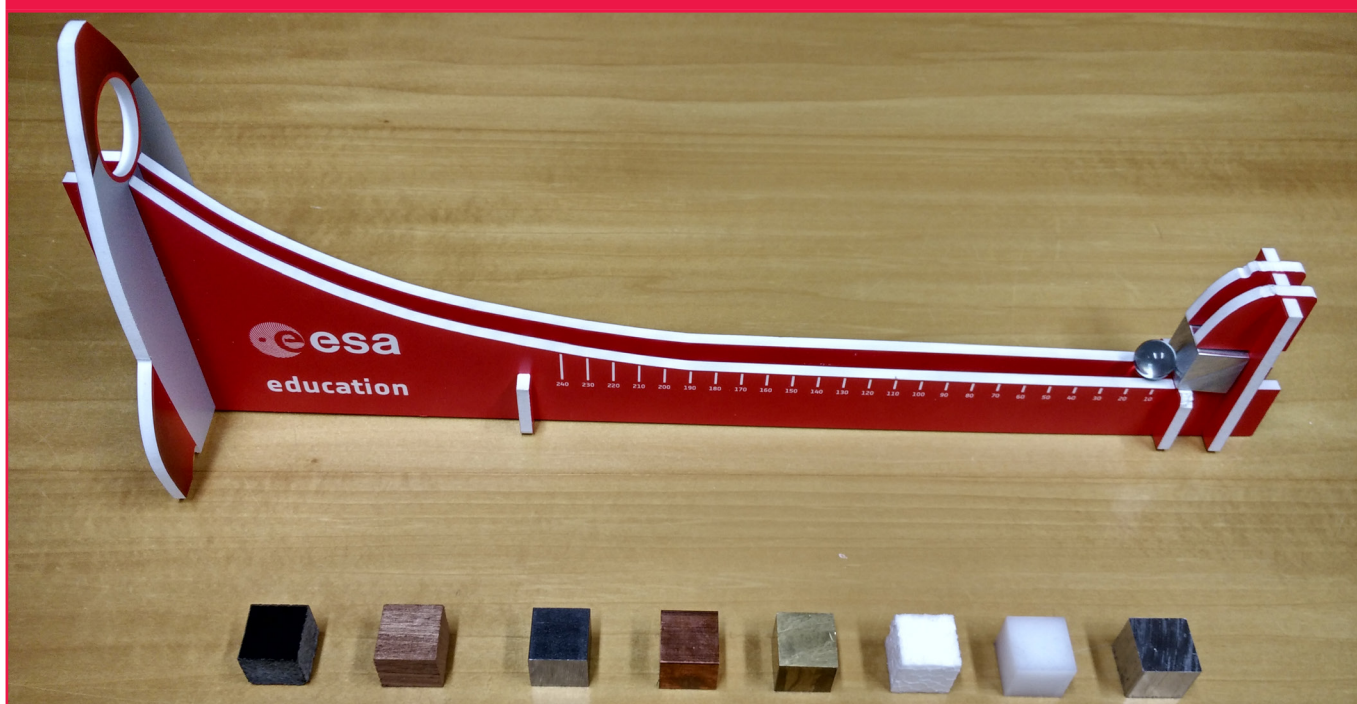

↑ Setup for the impact test



→ CLASSROOM DISCUSSION

Which materials appear to be best suited for a spacecraft?

In this activity, help the pupils fill in a table as shown below, where all their results can be displayed. Generate a class discussion and guide pupils into thinking about the different parts of the spacecraft and what kinds of materials would best be suited for which purpose. Have them write down the reasons for their choices in the pupil activity sheet.

Below are some typical results for all the tests as an indication only (measures may differ depending on the individual kits and the scale used).

material	look and feel	electrical conductivity (Yes/No)	thermal conductivity (ranking)	measuring mass (g)		magnetism (Yes/No)	measuring impact rebound (mm)	
				(g)	(ranking)		(mm)	(ranking)
Copper	Shiny, cold, heavy	Yes	5	71	9	No	100	5
Aluminium	Shiny, cold, light	Yes	2	22	4	No	30	7
Brass	Shiny, cold, heavy	Yes	4	67	8	No	170	2
Steel	Shiny, cold, heavy	Yes	6	61	7	Yes	150	3
Wood	Dull, warm, light	No	9	5-8	2	No	10	8
Stone	Dull, cold, quite heavy	No	3	24	6	No	80	5
Plastic	Dull, cold, light	No	7	7.6	3	No	0	9
Polystyrene	Dull, warm, light	No	8	0.1	1	No	210	1
Aluminium alloy (6061)	Shiny, cold, quite light	Yes	1	23	5	No	40	6



→ APPENDIX

Glossary of terms in pupil activity sheets

Electrical conductor: material which allows the flow of electric current e.g. metal.

Habitat: place or environment where humans, animals, and plants can live.

Heat of re-entry: heat generated by the re-entry of a spacecraft into the atmosphere; temperatures can reach 1650° Celsius or more.

Honeycomb: network of close-fitting hexagonal cells that create a very strong structure which is also light in weight.

Impact: collision of space debris with satellites or spacecraft like the International Space Station which can cause damage due to the high speed at which they travel.

Insulator: material which does not allow the flow of electric current e.g. plastic and wood.

Module: detachable, self-contained unit of a spacecraft.

Phenolic resin: very strong synthetic substance used for its strong temperature tolerance.

Propulsion: force that pushes a spacecraft into space.

Resin: yellow or brown sticky substance that comes from some trees and is used to make various products.

Rocket fuel: explosive charge that propels a rocket e.g. liquid oxygen and liquid hydrogen.

Satellites (artificial): objects put into orbit (which is a repeated path) around the Earth or another planet. Satellites are designed to take measurements and pictures which will, for instance, help scientists learn more about the Earth, planets, and beyond.

Spacecraft: vehicle used for travelling in space e.g. the International Space Station and Orion spacecraft.

Space debris: pieces of old satellites, used rocket parts, fragments of space rocks etc. which are travelling at high speeds of up to 28 000 km/h around the Earth.

Links

The Orion mission

The Orion spacecraft:

www.esa.int/Our_Activities/Human_Spaceflight/Orion/What_is_Orion

Parts of the Orion spacecraft:

www.esa.int/spaceimages/Images/2015/11/Orion_spacecraft_exploded_view

The Orion Mission:

www.esa.int/Our_Activities/Human_Spaceflight/Orion/Exploration_Mission_1

ESA resources

ESA classroom resources:

www.esa.int/Education/Classroom_resources

ESA kids homepage:

www.esa.int/esaKIDSen

Paxi Fun Book:

<http://esamultimedia.esa.int/multimedia/publications/PaxiFunBook>

teach with space – spacecraft materials kit | PR07a
www.esa.int/education

Concept developed for ESA by Nottingham Trent University, UK

The ESA Education Office welcomes feedback and comments
teachers@esa.int

An ESA Education production
Copyright © European Space Agency 2017